

Waterproof ReSet Call Point Series 01, 02 & 11

The IP 67 Waterproof ReSet (WRP) has been designed to deal with today's difficult and harsh environments. Like the ReSet Call Point it is a unique fire alarm manual Call Point that mimics the feel of breaking glass whilst offering the user the benefits and safety advantages of a glass-free resettable operating element. Once activated a warning flag drops in to view easily identifying the Call Point that has been operated. A key can then reset the unit. The Waterproof ReSet provides an ideal solution for most conventional fire alarm systems. Ideal for all outside applications such as oil rigs, ships, factory's as well as wash down areas that are sensitive to broken glass.

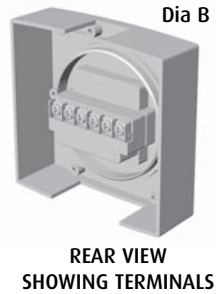

IMPORTANT NOTICE

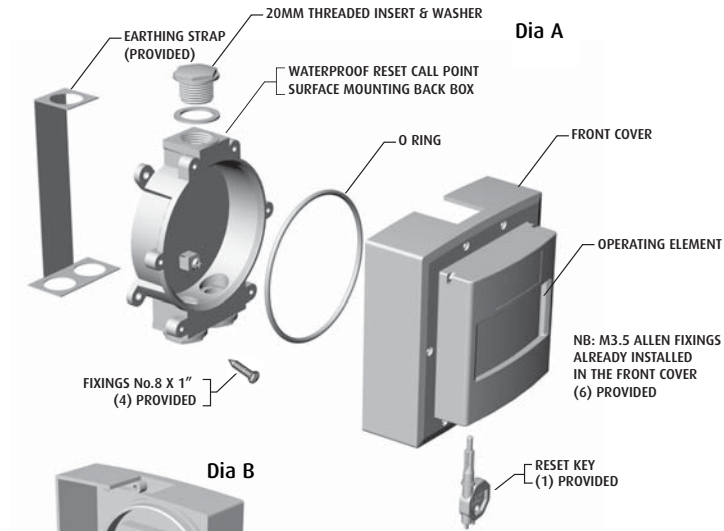
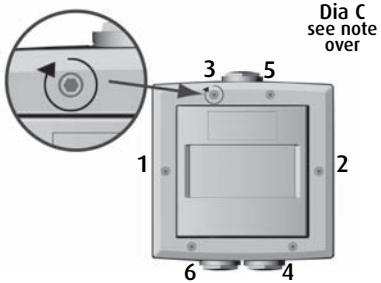

Dia C see note over

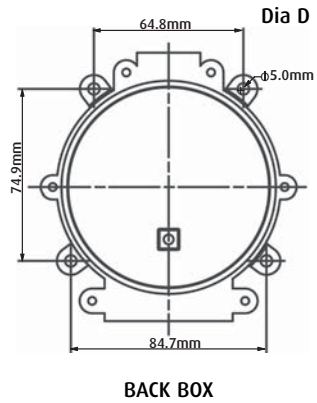

Connection Options for Waterproof ReSet Call Point Series 01

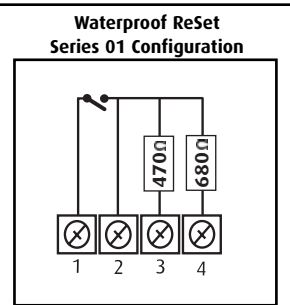

Option 1 terminals 1 & 2
Normally open switch closing on alarm

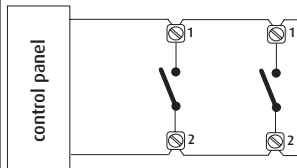

Option 2 terminals 1 & 3
Normally open switch closing on alarm with a 470 ohm resistor fitted in series with the switch

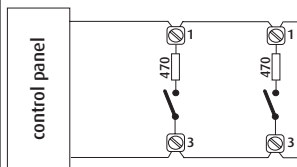

Option 3 terminals 1 & 4
Normally open switch closing on alarm with a 680 ohm resistor fitted in series with the switch

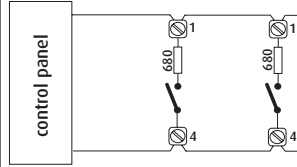

Waterproof ReSet Call Point Series 01, 02 & 11

The IP 67 Waterproof ReSet (WRP) has been designed to deal with today's difficult and harsh environments. Like the ReSet Call Point it is a unique fire alarm manual Call Point that mimics the feel of breaking glass whilst offering the user the benefits and safety advantages of a glass-free resettable operating element. Once activated a warning flag drops in to view easily identifying the Call Point that has been operated. A key can then reset the unit. The Waterproof ReSet provides an ideal solution for most conventional fire alarm systems. Ideal for all outside applications such as oil rigs, ships, factory's as well as wash down areas that are sensitive to broken glass.

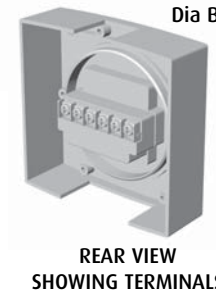
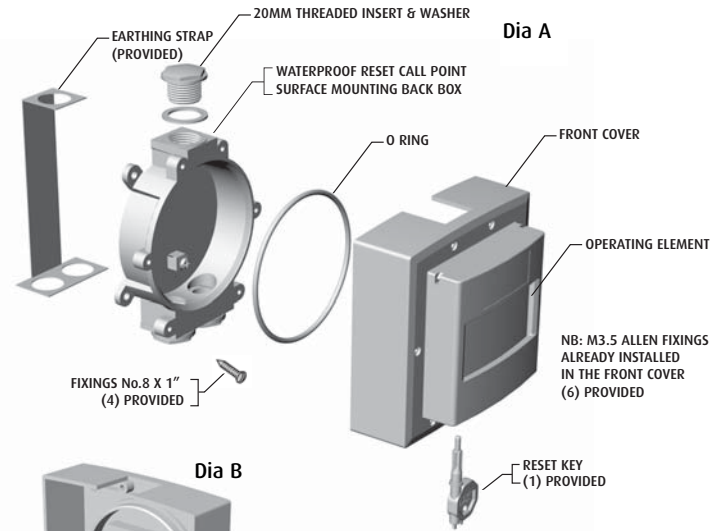

IMPORTANT NOTICE

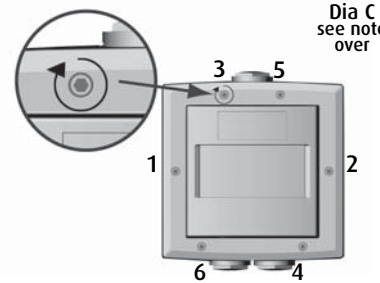

Dia C see note over

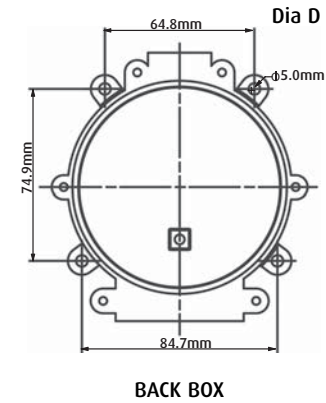

Connection Options for Waterproof ReSet Call Point Series 01

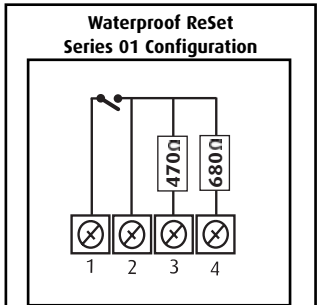

Option 1 terminals 1 & 2
Normally open switch closing on alarm

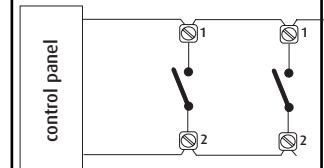

Option 2 terminals 1 & 3
Normally open switch closing on alarm with a 470 ohm resistor fitted in series with the switch

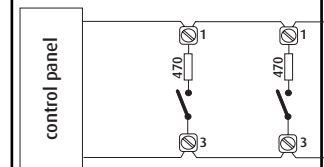

Option 3 terminals 1 & 4
Normally open switch closing on alarm with a 680 ohm resistor fitted in series with the switch

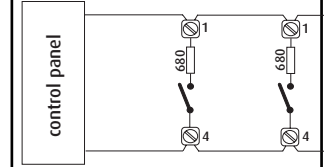

Technical Data for Waterproof Reset Call Point Series 01, 02 & 11

Specifications

Current Rating (Series 01, 02 & 11)	3 Amps 12 - 24V DC
	3 Amps 125 - 250V AC
Current Rating (Series 11 only)	3 Amps 125 - 250V AC
Housing and Mounting Box Material	Polycarbonate
Electrical Contact Material	Silver plated brass
Operating Temperature	-20°C - +65°C
Installation Terminal Conductor Size	0.5mm - 2.5mm

Waterproof Reset Series 01 & 11

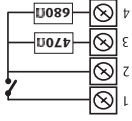

Waterproof Series 01
Denotes a Waterproof Reset Call Point that will interface with most conventional fire alarm systems. It is fitted with two internal 1 watt resistors 470 and 680 ohm. These are easily accessed through the installer terminals as illustrated.

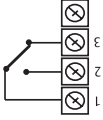

Waterproof Series 02
Denotes a Waterproof Reset Call Point that is fitted with a single pole changeover switch. Both the normally open and normally closed contacts are easily accessed through the installer terminals as illustrated.

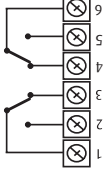

Waterproof Series 11
Denotes a Waterproof Reset Call Point that incorporates two independent single pole changeover switches providing double pole changeover contacts. Easily accessed through installer terminals as illustrated.

NB: Switch arrangements shown with WRP Reset in standby.



Safety Technology International (Europe) Limited
Unit 496 - Pipes Road - Park Farm Ind. Est. - Redditch
Worcestershire - B98 0HU - England
Tel: +44 (0) 1527 520 999 - Fax: +44 (0) 1527 501 999
E mail: info@sti-europe.com - Web Site: www.sti-europe.com



10Waterproof-Reset_Series01,02&11 - Revised 10/09-04Z - Printed in England

Need help? Call our Technical Support Team on Freephone 0800 085 1678 (UK) Tel: 44 (0)1527 520999 (UK & Europe)

Mounting Method

- Remove the Waterproof Reset Call Point (WRP) from its packaging. Detach the front cover from the backbox. You have a choice to keep or remove the earthing strap.
- Ensure the conduit or cabling lines up with the conduit entries located on the top or bottom of the back box and remove the desired conduit threaded insert(s). It is recommended that entry to the WRP is via the one or two 20mm threaded entries on the bottom of the back box.
- Take the back box (ensuring the two entries are located at the bottom) and mark the position for the four fixing screws.
- Drill the holes and install the back box using the four fixing screws and rawl plugs provided.
- When the wiring connections are complete, fix the front cover to the back box. There are x6 allen screws evenly distributed around the front cover. Using the allen key provided tighten each allen screw by one full turn, then move onto the next. This will ensure that even pressure is applied all the way around. See Dia C for recommendation on the sequence to be used. The recommended torque for the allen screws is 5 N-m.

In order to achieve IP67 rating, ensure the front cover is securely tightened to the back box.

Dimensions

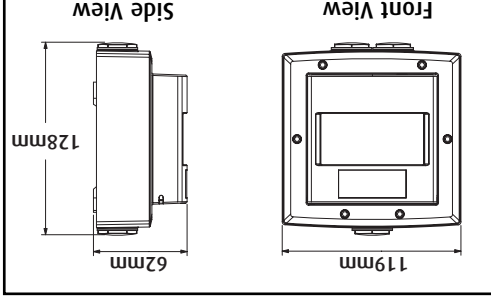

Accessories

ST1 F068	Allen Key
ST1 M210	WRP Test Key
ST1 F069	Earth Strap
ST1 C084	'O' Ring
ST1 M227	20mm Threaded Insert
ST1 M228	Waterproof Washer

Technical Data for Waterproof Reset Call Point Series 01, 02 & 11

Specifications

Current Rating (Series 01, 02 & 11)	3 Amps 12 - 24V DC
	3 Amps 125 - 250V AC
Current Rating (Series 11 only)	3 Amps 125 - 250V AC
Housing and Mounting Box Material	Polycarbonate
Electrical Contact Material	Silver plated brass
Operating Temperature	-20°C - +65°C
Installation Terminal Conductor Size	0.5mm - 2.5mm

Waterproof Reset Series 01 & 11

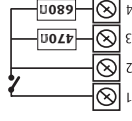

Waterproof Series 01
Denotes a Waterproof Reset Call Point that will interface with most conventional fire alarm systems. It is fitted with two internal 1 watt resistors 470 and 680 ohm. These are easily accessed through the installer terminals as illustrated.

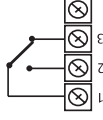

Waterproof Series 02
Denotes a Waterproof Reset Call Point that is fitted with a single pole changeover switch. Both the normally open and normally closed contacts are easily accessed through the installer terminals as illustrated.

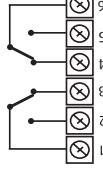

Waterproof Series 11
Denotes a Waterproof Reset Call Point that incorporates two independent single pole changeover switches providing double pole changeover contacts. Easily accessed through installer terminals as illustrated.

NB: Switch arrangements shown with WRP Reset in standby.



Safety Technology International (Europe) Limited
Unit 496 - Pipes Road - Park Farm Ind. Est. - Redditch
Worcestershire - B98 0HU - England
Tel: +44 (0) 1527 520 999 - Fax: +44 (0) 1527 501 999
E mail: info@sti-europe.com - Web Site: www.sti-europe.com



10Waterproof-Reset_Series01,02&11 - Revised 10/09-04Z - Printed in England

Need help? Call our Technical Support Team on Freephone 0800 085 1678 (UK) Tel: 44 (0)1527 520999 (UK & Europe)

Mounting Method

- Remove the Waterproof Reset Call Point (WRP) from its packaging. Detach the front cover from the backbox. You have a choice to keep or remove the earthing strap.
- Ensure the conduit or cabling lines up with the conduit entries located on the top or bottom of the back box and remove the desired conduit threaded insert(s). It is recommended that entry to the WRP is via the one or two 20mm threaded entries on the bottom of the back box.
- Take the back box (ensuring the two entries are located at the bottom) and mark the position for the four fixing screws.
- Drill the holes and install the back box using the four fixing screws and rawl plugs provided.
- When the wiring connections are complete, fix the front cover to the back box. There are x6 allen screws evenly distributed around the front cover. Using the allen key provided tighten each allen screw by one full turn, then move onto the next. This will ensure that even pressure is applied all the way around. See Dia C for recommendation on the sequence to be used. The recommended torque for the allen screws is 5 N-m.

In order to achieve IP67 rating, ensure the front cover is securely tightened to the back box.

Dimensions

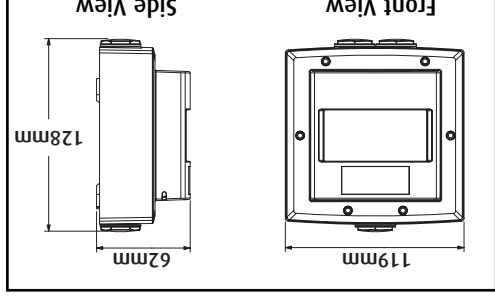

Accessories

ST1 F068	Allen Key
ST1 M210	WRP Test Key
ST1 F069	Earth Strap
ST1 C084	'O' Ring
ST1 M227	20mm Threaded Insert
ST1 M228	Waterproof Washer